

**IP Rugged Dome
CAM-7100/CAM-7101**

User's Manual

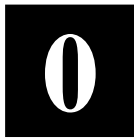

www.acti.com



PRECAUTIONS

1. Read these instructions

All the safety and operating instructions should be read before the product is operated.

2. Heed all warnings

All warnings on the product and in the instruction manual should be adhered to.



The symbol indicates the following items, please carefully read the description next to each symbol.

- a. Failure to follow the safety instruction given may directly endanger people, cause damage to the system or to other equipment.
- b. The requirements to make this device work, including hardware, computer settings, network settings, and operation procedures.
- c. The tips to make using this device easier, more convenient and more efficient.

3. Servicing

Do not attempt to service this video product yourself as opening or removing covers may expose you to dangerous voltage or other hazards. Refer all servicing to qualified service personnel.

Copyright

This manual is the intellectual property of ACTi and is protected by copyright. All rights are reserved. No part of this document may be reproduced or transmitted for any purpose by any means including electronic or mechanical without the official written permission from ACTi.

Trademarks

All names used in this manual for hardware and software are probably registered trademarks of respective companies.

Liability

Every care has been taken during writing this manual. Please inform your local office if you find any inaccuracies or omissions. We cannot be held responsible for any

typographical or technical errors and reserve the right to make changes to the product and manuals without prior notice.

FCC/CE Regulation

NOTE: This equipment has been tested and found to comply with the limits for a Class B digital device, pursuant to Part 15 of the FCC Rules. These limits are designed to provide reasonable protection against harmful interference when the equipment is operated in a commercial environment. This equipment generates, uses, and can radiate radio frequency energy and, if not installed and used in accordance with the instruction manual, may cause harmful interference to radio communications. Operation of this equipment in a residential area is likely to cause harmful interference in which case the user will be required to correct the interference at his own expense.

Table of Contents

0	<i>PRECAUTIONS</i>	<i>0-1</i>
	Copyright	0-1
	Trademarks	0-1
	Liability	0-1
	FCC/CE Regulation	0-2
1	<i>INTRODUCTION</i>	<i>1-1</i>
1.1	Package Contents	1-1
1.2	Features and Benefits	1-2
1.3	Safety Instructions	1-4
1.4	Physical Description	1-6
1.5	Mounting the IP Rugged Dome	1-10
1.6	Basic Connections	1-11

1

INTRODUCTION

1.1 Package Contents

CAM-7100/7101



Warranty Card



Product CD



Terminal Blocks for Power & DI/O



Power Adaptor



Accessory



1.2 Features and Benefits

The IP Rugged Dome is a cutting-edge digital video transmission device. It can compress and transmit real time images with outstanding images quality (D1, 720x480) at reasonable bandwidth through a standard TCP/IP network. That's because it is Ethernet (LAN and WAN) ready and has the powerful ARM9 SoC and the MPEG-4 compression ASIC inside. In addition, with these powerful hardware platform, excellent SDK support and powerful respective apparatuses (eg. the transcoder), this IP rugged dome is your best choice building up either conventional IP surveillance system or intelligent IP surveillance system.

- **Real-time MPEG-4 Compression**

With hardware MPEG-4 compression chip inside, the composite video inputs can be efficiently compressed into MPEG-4 bit stream without any delay. The ASIC base compression engine can support not only CIF, but also FULL D1 image resolution.

- **QoS Enabled Video Streaming**

For real-time video streaming requirements, the IP rugged dome implemented the 802.1pQ features inside the SoC as the streaming engine to make sure the video streaming package is forwarded faster than normal TCP/UDP packet.

- **Automatic Frame Rate Control**

The IP rugged dome supports automatic/manual streaming frame rate control, especially for multiple clients concurrent access the same video stream in different network bandwidth.

- **Digital Time Code Embedded**

The "Digital Time Code Embedded" function is to embed the recording time in the MPEG bit stream. Therefore, each image frame has its respective time when it was recorded. It is very useful when users want to find the video at an exact time or between a certain time intervals.

- **Build-in LAN and WAN (Low Latency PPPoE Supported) Ports**

The IP rugged dome provides two RJ-45 connectors. One is WAN and the other is LAN. The WAN port connects to the internet and LAN port connects to the local network. Since the internet's bandwidth is very critical, the WAN port is equipped with a low latency PPPoE

(Point-to-Point over Ethernet) which has excellent transmission speed and enables the IP rugged dome to connect to an ADSL or a cable modem.

- **DDNS Supported**

The IP rugged dome supports DDNS (Dynamic Domain Name Server), users can set the IP rugged dome at a virtual domain name (such as cam1.Taipei.xxx) at dynamic IP. Everyone can use the virtual domain name to view the video anywhere that has the access to the internet.

- **Build-in Hardware Motion Detection**

No more external motion sensors are required. Each IP rugged dome can be set up to 3 detection areas. By tuning the object size and sensitivity, it is very reliable to fit into your environment. Besides, hardware motion detection delivers better sensitivity and respond faster than software motion detection.

- **Bundle Powerful Surveillance Software**

To extend the capabilities of the IP rugged dome, a powerful surveillance program is included in the package and is totally free to use. Users can easily utilize the existing PC to be a digital video recorder. Schedule recording and manual recording keep every important image recorded in the local hard disk. Reliable and accurate motion detection with instant warning makes you responsive in every condition. Quick and simple search and playback function lets you easily find the images you want.

- **Software Development Kit Support**

The IP rugged dome can be integrated or controlled by user's application program through the Streaming Library or ActiveX control. With its high level programming interface, software developer's time and efforts to is highly reduced.

1.3 Safety Instructions

- **Don't use the power supply with other voltages**

This device is likely to be damaged or damage other equipments / personnel, if you use a power supply with different voltage than the one included with this device. All warranty of this product will be voided in the situations above.

- **Don't open the housing of the product**

- **Cleaning**

Disconnect this video product from the power supply before cleaning.

- **Attachments**

Do not use attachments not recommended by the video product manufacturer as they may cause hazards.

- **Water and Moisture**

Do not use this video product near water, for example, near a bathtub, washbowl, kitchen sink, or laundry tub, in a wet basement, or near a swimming pool and the like.

- **Don't use accessories not recommended by the manufacturer**

- **Only install this device and the power supply in a dry place protected from weather**

- **Servicing**

Do not attempt to service this video product yourself as opening or removing covers may expose you to dangerous voltage or other hazards. Refer all servicing to qualified service personnel.

- **Damage Requiring service**

Disconnect this video product from the power supply immediately and refer servicing to qualified service personnel under the following conditions.

1. When the power-supply cord or plug is damaged.
2. If liquid has been spilled, or objects have fallen into the video product.
3. If the video product has been exposed to rain or water directly.
4. If the video product does not operate normally by following the

operating Instructions in this manual. Adjust only those controls that are covered by the instruction manual as an improper adjustment . Other controls may result in damage and will often require extensive work by a qualified technician to restore the video product to its normal operation.

- **Safety Check**

Upon completion of any service or repairs to this video product, ask the service technician to perform safety checks to determine that the video product is in proper operating condition.

1.4 Physical Description

Rugged Dome Rear Panel

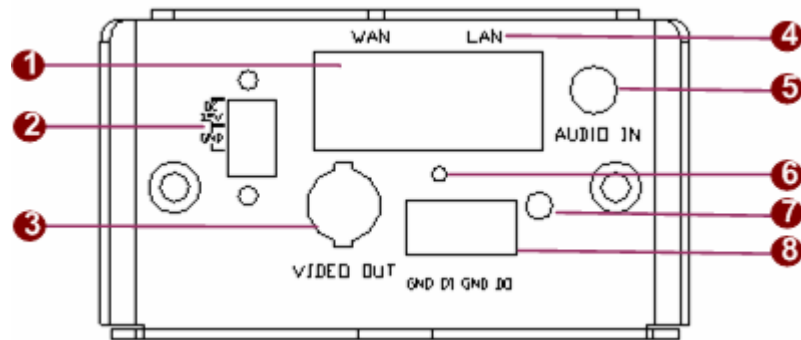

1. WAN port

The IP rugged dome connects to the WAN (wide area network) via a standard RJ45 connector. Supporting NWAY, this IP rugged dome can auto detect the speed of local network segment (10Base-T/100Base-TX Ethernet). The WAN port is for FTTH and can connect to a xDSL or cable modem.

With PoE built-in product, you can power the IP rugged dome via WAN port, LAN port or DC input. You can power the IP rugged dome with multiple power inputs at the same time. If you do, the IP rugged dome will get the power from the first power input plugged into it.



NOTE: You may find a support package for help you getting familiar with PoE. Please visit our web site, and get the support document TS-00040.

2. Power Input

DC 12V input.



PIN	NAME	DESCRIPTION
1	12V	Power Input (DC +12V)
2	GND	Ground Pin of Power Input
3	X	No Connection

With PoE built-in product, you can power the IP rugged dome via

WAN port, LAN port or DC input. You can power the IP rugged dome with multiple power inputs at the same time. If you do, the IP rugged dome will get the power from the first power input plugged into it.



NOTE: You may find a support package for help you getting familiar with PoE. Please visit our web site, and get the support document TS-00040.

3. **Analog Video Output**

The IP rugged dome supports one channel analog video output.

4. **LAN port**

The IP rugged dome connects to the LAN (local area network) via a standard RJ45 connector. Supporting NWAY, this IP rugged dome can auto detect the speed of local network segment (10Base-T/100Base-TX Ethernet).

With PoE built-in product, you can power the IP rugged dome via WAN port, LAN port or DC input. You can power the IP rugged dome with multiple power inputs at the same time. If you do, the IP rugged dome will get the power from the first power input plugged into it.



NOTE: You may find a support package for help you getting familiar with PoE. Please visit our web site, and get the support document TS-00040.

5. **Audio Input**

Unbalanced, 1.0Vpp, 1Vrms, 3.5mm Jack

6. **Reset Button**

Step 1: Switch off IP rugged dome by disconnecting the power cable

Step 2: Using a suitable pointed object, press and continue to hold the Reset Button depressed. While continuing to hold the reset button depressed, reconnect the power cable.

Step 3: Keep holding the reset button depressed around 6 seconds, release the reset button. The unit will start up with factory default settings.

7. **Action LED Indicator**

The LED will light up after IP rugged dome has successfully completed the boot process.

8. **DI/O**

The IP rugged dome supports one alarm input and one alarm output. DI:Logic Level 0: 0~0.4V; Logic Level 1: 3.3~30V
DO:Logic Level 0: 0.1~0.6V; Logic Level1: 2.4~5V



PIN	NAME	DESCRIPTION
1	GND	Ground Pin
2	DI	Digital Input
3	GND	Ground Pin
4	DO	Digital Output

Camera Dip Switch

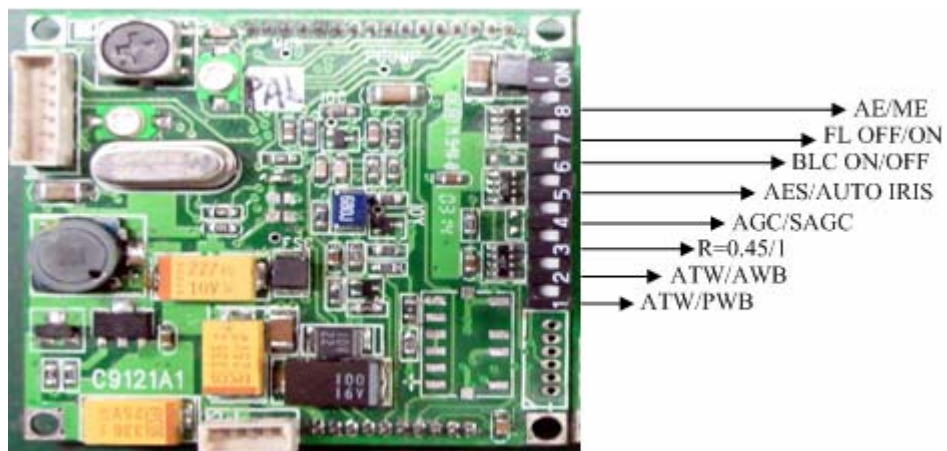
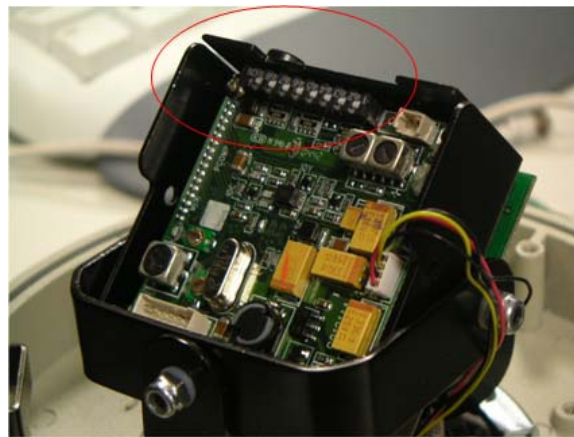

Pin	Low	Hi(ON)(3.3v)
8	AE	ME
7	FL OFF	FL ON
6	BLC ON	BLC OFF
5	AES	Auto Iris
4	AGC	Super AGC
3	r =0.45	r = 1
2	ATW	AWB
1	ATW	PWB

SHUTTER SPEED	AE/ME			
1/50 (1/60) SEC	ME	FL OFF	BLC	AEC
1/120 (1/100) SEC	ME	FL	BLC	AEC
1/250 SEC	ME	FL OFF	BLC OFF	AEC
1/500 SEC	ME	FL	BLC OFF	AEC
1/1000 SEC	ME	FL OFF	BLC	AUTO IRIS
1/2000 SEC	ME	FL	BLC	AUTO IRIS
1/4000 SEC	ME	FL OFF	BLC OFF	AUTO IRIS
1/10000 SEC	ME	FL	BLC OFF	AUTO IRIS

AWB mode – Conventional auto white balance

Procedure: Pin 2 set to High first, and then set Pin 1 to Low.

ATW mode – The operating colour temperature range is from 2500°K to 9500°K approximately.

Procedure: Pin 2 set to Low first, and then set Pin 1 to Low.

PWB mode – Push to lock white balance

Procedure: Pin 2 set to High first, and then set Pin 1 to High.

1.5 Mounting the IP Rugged Dome

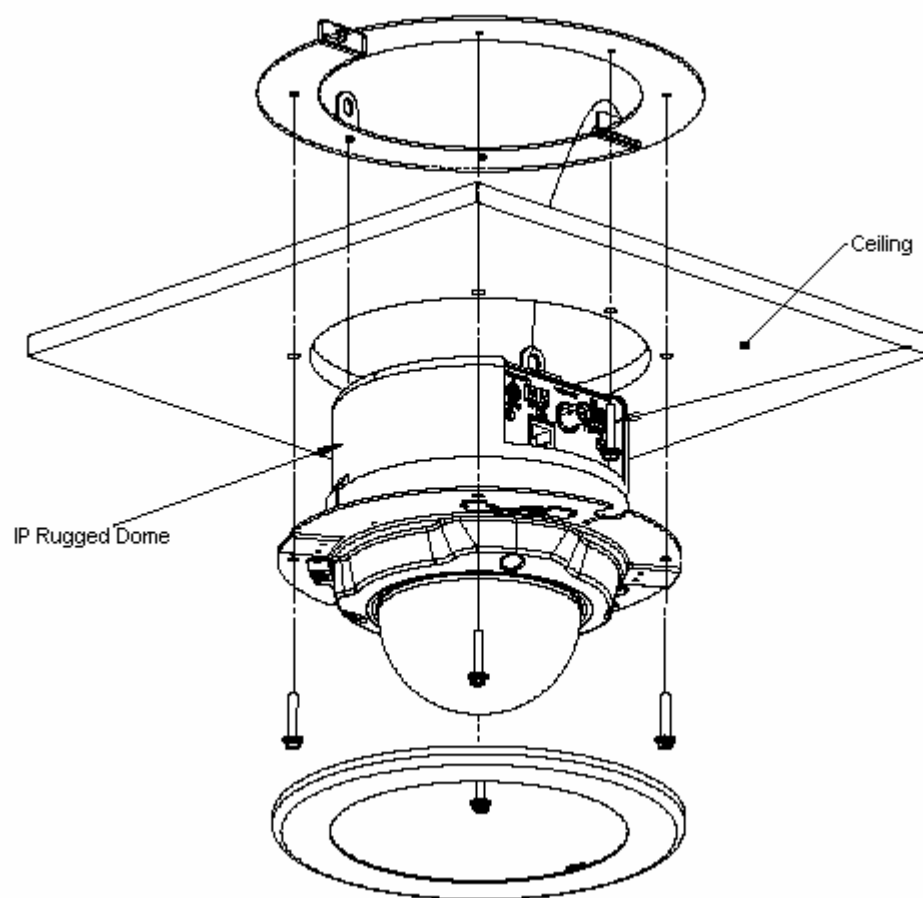

1.6 Basic Connections

Follow the procedures below to connect the IP rugged dome to the respective apparatuses.

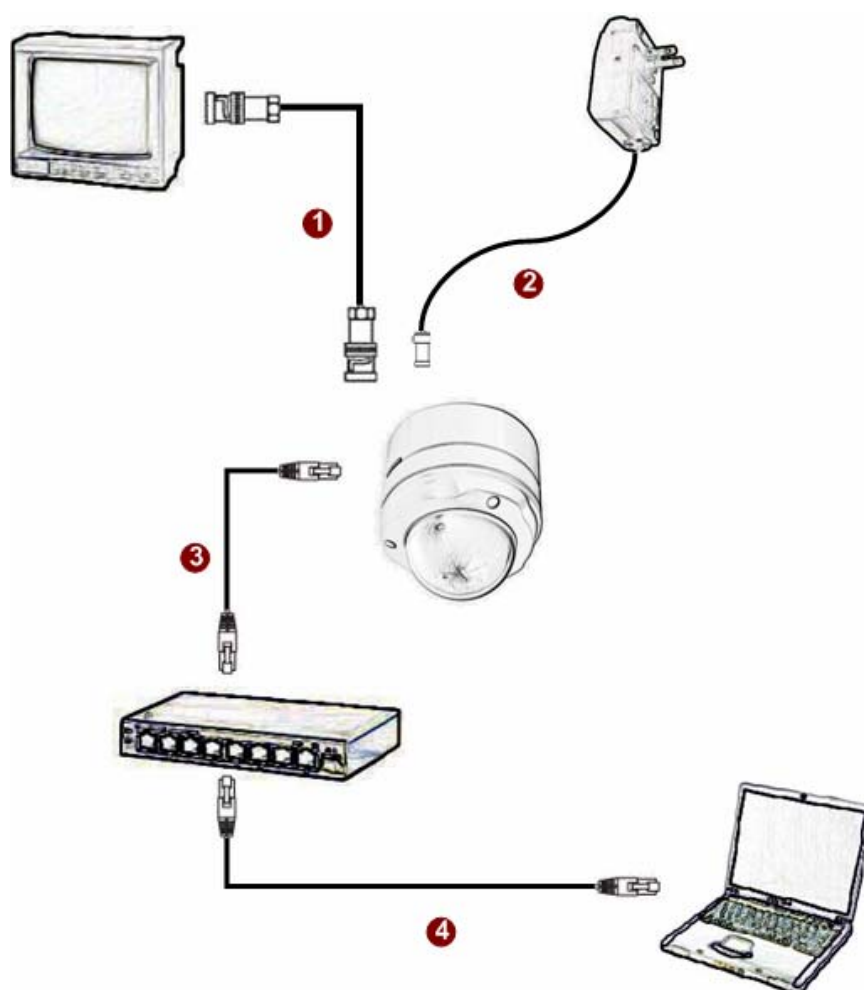

1. Connect an analog monitor to IP rugged dome video out (BNC connector).
2. Connect the power adaptor to IP rugged dome
3. Connect IP rugged dome's LAN port to an Ethernet (RJ45 connectors). If

your IP rugged dome has PoE built-in, you can regard it as a PD and connect it directly to a PSE device like PoE switch.

4. Connect a PC to the Ethernet hub (RJ45 connectors)



NOTE: You may find a support package for help you getting familiar with PoE. Please visit our web site, and get the support document TS-00040.